

JOB NAME: \_\_\_\_\_ DATE: \_\_\_\_\_  
 DOOR LOCATION: \_\_\_\_\_ DOOR NO: \_\_\_\_\_ SHEET \_\_\_ OF \_\_\_

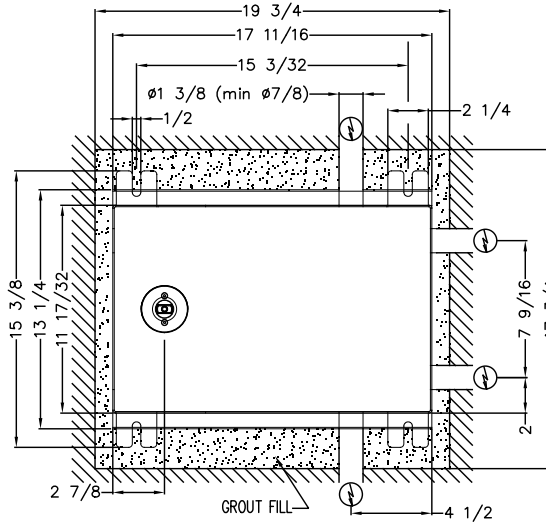
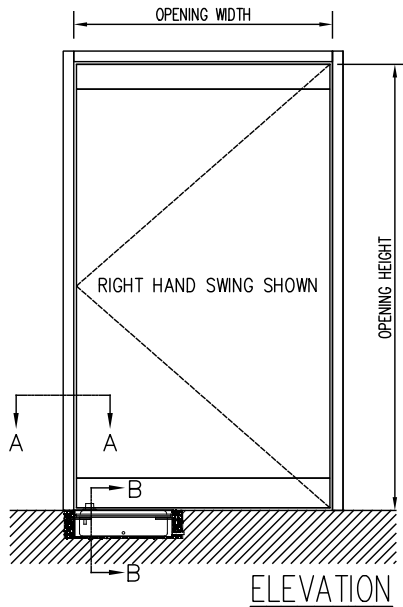

OPERATOR AND FLOOR BOX  
 TOP VIEW

**FLUSH MOUNT-TERRAZZO PAN**  
 - SPECIAL REMOVABLE COVER BOX FOR  
 FLOOR COVERING INSTALLATION  
 - MAX. FLOOR COVERING = 3/4"

**PIT DIMENSION**  
 19 3/4"L x 17 3/4"W x 6 7/8"D

FLUSH MOUNT FLOOR BOX

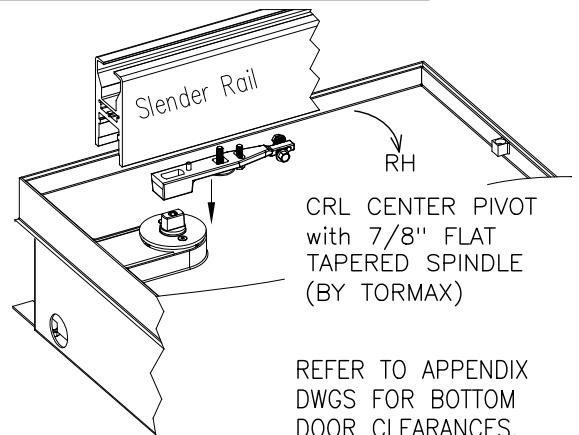
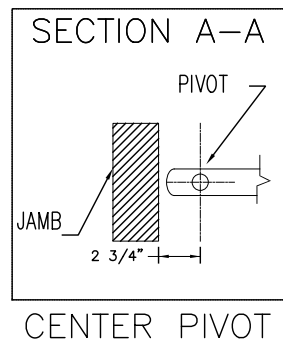
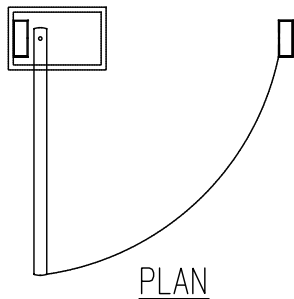
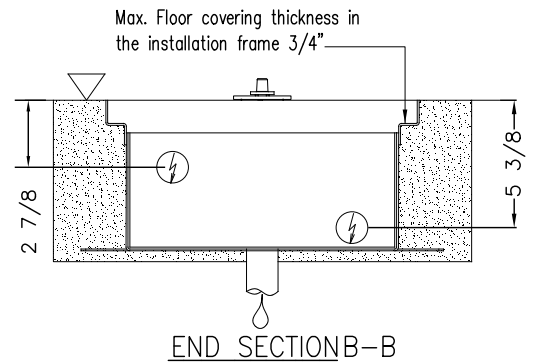
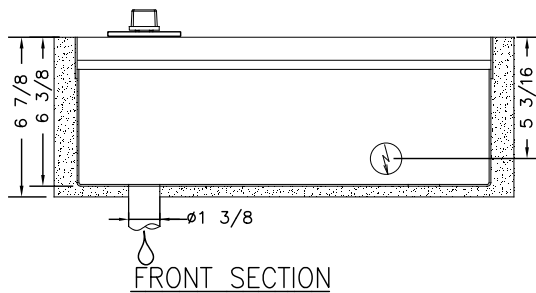

- ▽ Concrete or Finished Floor
- 💧 Weep Drain Required
- ⚡ Possible Electrical Feed

NOTES:

1. DETAILS NOT TO SCALE.
2. ELECTRICAL REQUIREMENTS:  
 120VAC, 15AMP MIN. TO EACH CONTROLLER LOCATED REMOTE FROM OPERATOR. LOW VOLTAGE CONDUIT RUN FROM EACH CONTROLLER TO OPERATOR BY ELECTRICAL CONTRACTOR.
3. DOORS, FRAMES AND HARDWARE BY OTHERS. BOTTOM DOOR PIVOT BY TORMAX.
4. 32" CLEAR DOOR OPENING REQUIRED TO MEET A.D.A. REQUIREMENTS.
5. DOORS MUST BE NON-LATCHED FOR PROPER OPERATION.
6. OPERATOR CAN BE CONFIGURED TO MEET ANSI STANDARDS A156.10 & ANSI A156.19

REFER TO APPENDIX  
 DWGS FOR BOTTOM  
 DOOR CLEARANCES,  
 RAIL PROFILES & PIVOTS