

DUAL INDEPENDENT OPERATION, VISIBLE R.H. INSWING,
 R.H. OUTSWING, CENTER PIVOT NON-PANIC APPLICATION

JOB NAME: _____ DATE: _____

DOOR LOCATION: _____ DOOR NO: _____ SHEET _____ OF _____

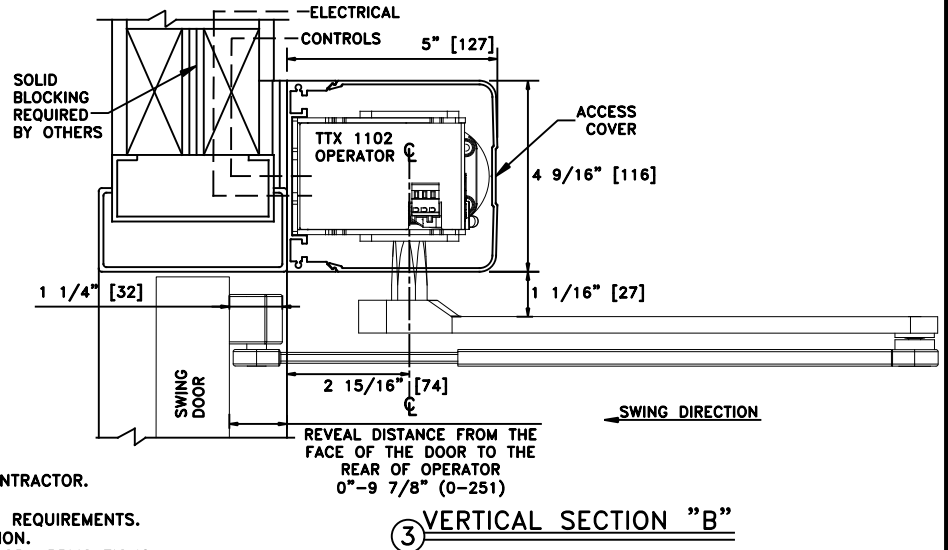
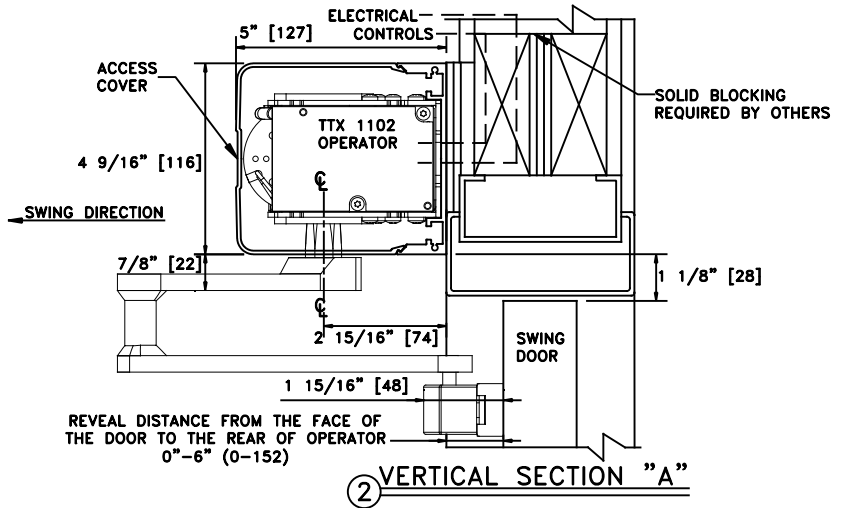
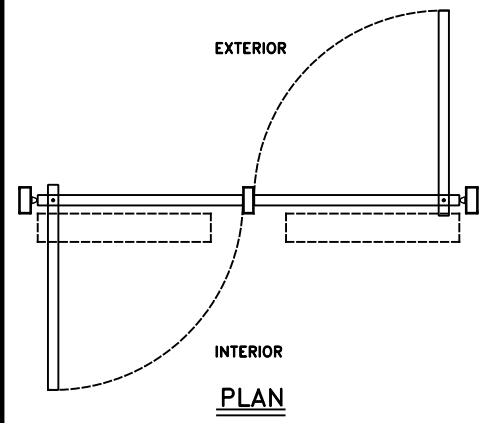
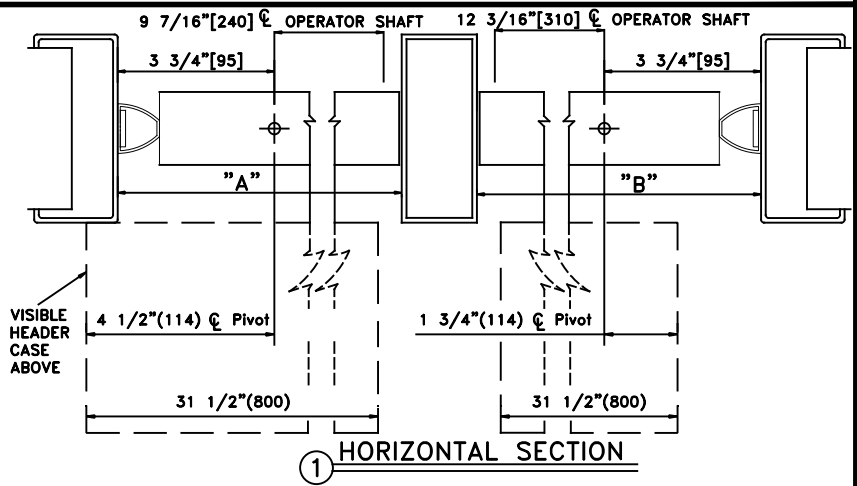
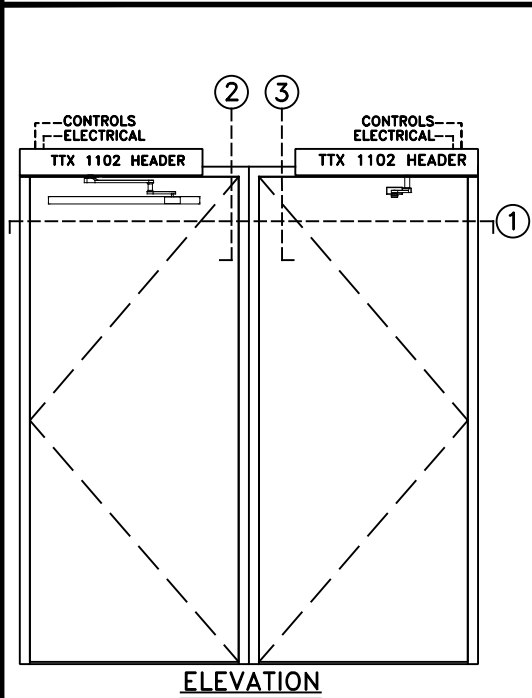

- NOTES:**
1. DETAILS NOT TO SCALE.
 2. ELECTRICAL REQUIREMENTS:
 120VAC, 5AMPS MIN. TO OPERATOR BY ELECTRICAL CONTRACTOR.
 3. DOORS, FRAMES AND HARDWARE BY OTHERS.
 4. 32" CLEAR DOOR OPENING REQUIRED TO MEET A.D.A. REQUIREMENTS.
 5. DOORS MUST BE NON-LATCHED FOR PROPER OPERATION.
 6. OPERATOR HEADER IS AVAILABLE FOR FULL WIDTH DOOR APPLICATIONS.