

JOB NAME: \_\_\_\_\_ DATE: \_\_\_\_\_  
 DOOR LOCATION: \_\_\_\_\_ DOOR NO: \_\_\_\_\_ SHEET \_\_\_\_ OF \_\_\_\_

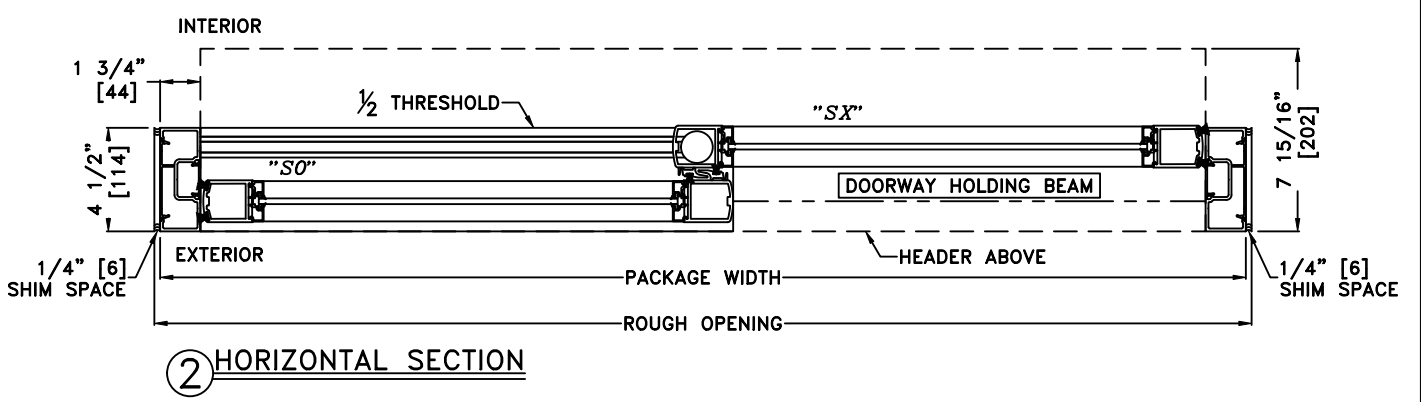
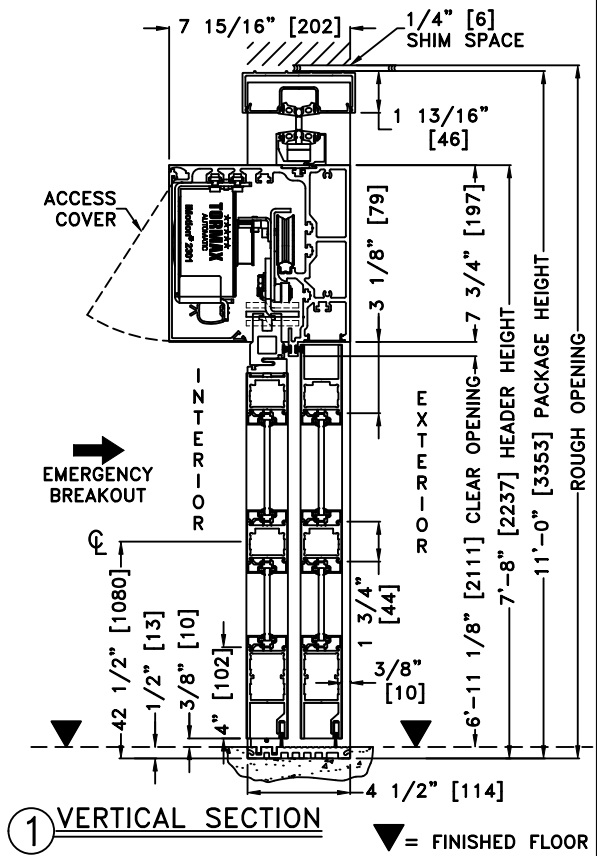
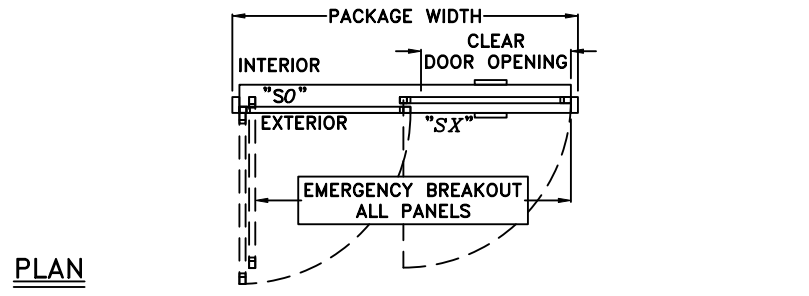
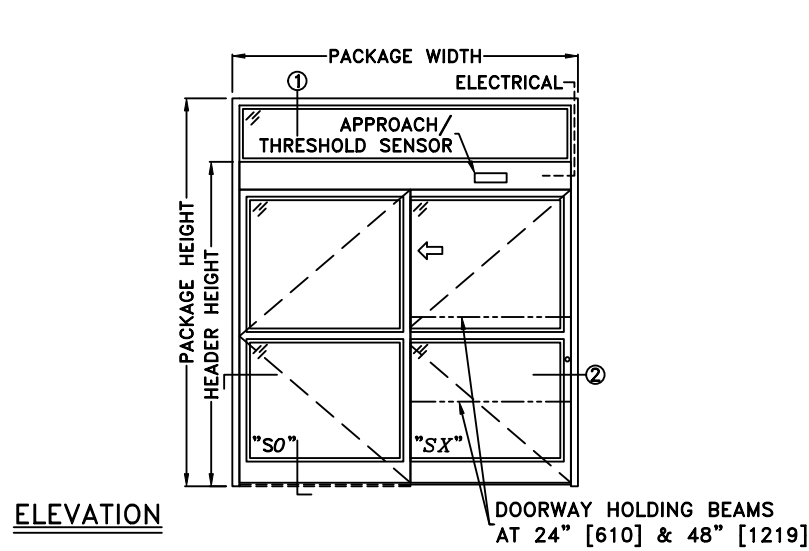

\*SEE APPENDIX FOR DETAILS OF TX9300 HEAVY DUTY DRIVE SYSTEM AND THRESHOLD OPTIONS

- NOTES:  
 1. DETAILS NOT TO SCALE  
 2. ELECTRICAL REQUIREMENTS: 120 VAC, 5 AMPS MIN. TO OPERATOR BY ELECTRICAL CONTRACTOR  
 3. DOOR PACKAGES ARE INDIVIDUALLY ENGINEERED TO FIT YOUR JOB REQUIREMENTS

SAMPLE PACKAGE WIDTH INFORMATION			
PACKAGE WIDTH [UW] (*)	CLEAR DOOR OPENING [CDO] (*)	PANEL WIDTH [PW] (*)	EMERGENCY BREAKOUT WIDTH (*)
2*[CDO] + 13 3/8	[UW]/2 - 6 1/16 -OR- [PW] - 6 1/8	[UW]/2 - 9/16	[UW] - 9
7'-0" [2134]	35 5/16" [897]	41 7/16" [1053]	75" [1905]
8'-0" [2438]	41 5/16" [1049]	47 7/16" [1205]	87" [2210]
9'-0" [2743]	47 5/16" [1202]	53 7/16" [1357]	99" [2515]
(*) CALCULATIONS BASED ON EQUAL PANELS, 2 1/8" NARROW STILES, & 1/4" GLASS			